

Life Cube-HC HARD CUBE

The industry's first:

- High Tech
- Quick response
- Hard-wall
- Portable
- Off-Grid
- Air droppable shelter

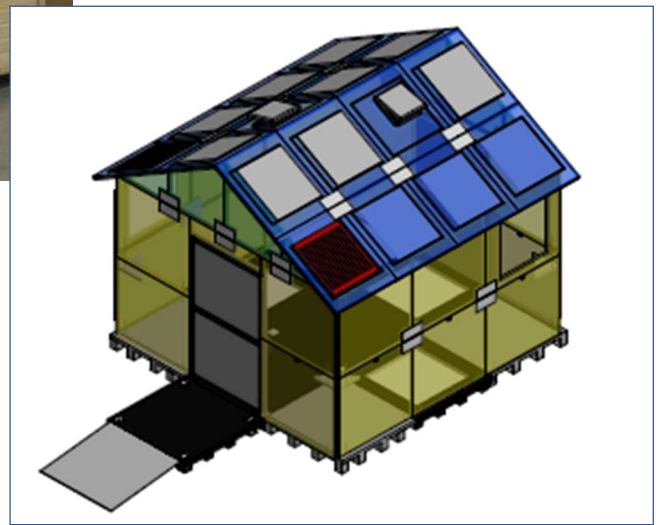
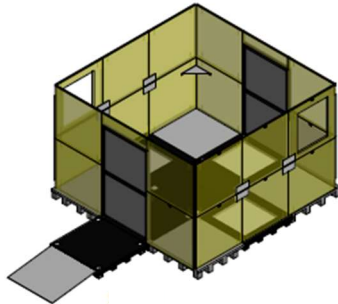
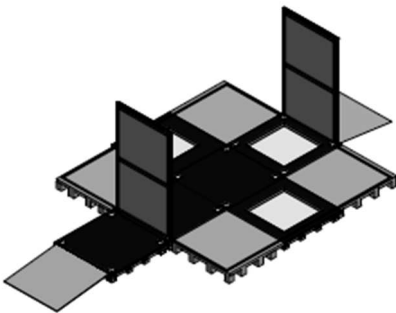

The Complete Mobile Solution

The Life Cube-HC (Hard Cube) is an insulated, hard-wall mobile shelter utilizing our patented interlocking foam panels which are coated in a proprietary Polyurethane formulation for added strength, insulation and durability. Aluminum infrastructure supports and a light-weight strapping design provide a secure structure, setting the Life Cube apart from all other rigid wall units. Stackable, storable, mobile.



5' shipping container is designed to be rolled into place for quick deployment, transforming into a sterilizable hard surface floor.



- 32 Insulated Panels
- Power within a floor hatch
- Dashboard provides all controls



The Debut of Lithium Floor Power

Life Cube-HC

HARD CUBE

The Life Cube-HC is a ready-to-deploy mobile shelter or medical platform designed for command and control, first responders, patient in-take, testing, isolation, and treatments with off-grid and wash-down capabilities.

The Premier Portable Unit

Store in your parking lot, deploy when needed. Developed in collaboration with military and health care professionals, the Life Cube is the ultimate solution for pre-positioning rapid response assets. Designed to be stored fully supplied, units can be stacked and pulled from inventory when needed. Integrated rolling hoops create an easily positioned mobile medical platform with a sterile, highly customized interior.

Square footage	160 sq. feet plus sleeping loft
Dimensions	12' x 12' x 12' + Porch + Loft
Interior Space	1331 cubic feet
Loft	125 sq. ft
Walls	Highly Insulated Foam Panels
Port	Standard 12" ECU port
Shore Power Inlet	Available per user requirement
Floor elevation	6"
Lighting	LED
Water Pump	12-volt water transfer pump
Power	Up to 2000 watts off-grid solar
Propane Unit	Optional for air & water heating
Heat	Solar hot-water heat

Features

- Rigid hard surface raised floor
- Lighting and solar power system
- Two windows, two doors
- Integrated solar panels, conditioner, inverter
- Rain water collection system
- Sleeping loft for six plus ample storage
- One covered entryway-vestibule
- HazMat decontamination wash-down
- Fuel and water storage within the floor
- Water purification, water filter
- Additional exterior water storage

Options

- Shower, sink, drainage
- Custom colors available
- Premium insulation package
- Additional hallway connections and windows, daisy-chainable units
- Airlock isolation capabilities
- ECU for heating/cooking, generator required
- Air filtration system
- Power upgrade available
- Fire proof and Ballistic materials available



LIFE CUBE INC.

Shelter Systems for Life

www.lifecubeinc.com

Tel: 805-708-6141

Email: info@lifecubeinc.com

Federal Contractor Cage Code 61YX6